

UNICARRIERS[®]

□ FORKLIFT □

Platinum GO6 Series



Engine Powered Forklifts

Diesel

15,500 – 22,000 lbs. Capacities | Pneumatic Tire



S P E C I F I C A T I O N S

MAIN TRUCK SPECIFICATIONS

CHARACTERISTICS	1	Manufacturer's Name		UniCarriers	UniCarriers	UniCarriers	
	2	Model	Model designation	FD70-2	FD80-2	FD100-2	
	3		Long model code	L1F6F70M	L1F6F80M	L1F6F100M	
	4	Power Type		Diesel	Diesel	Diesel	
	5	Rated Load Capacity	lb (kg)	15,500 (7000)	17,500 (8000)	22,000 (10,000)	
	6	Load Center	Distance	in (mm)	24 (600)	24 (600)	
	7	Operator Orientation		Sit	Sit	Sit	
DIMENSIONS	8	Tire Type	Front & rear	Pneumatic	Pneumatic	Pneumatic	
	9	Wheels	Number - front/rear(x=driven)	4x / 2	4x / 2	4x / 2	
	10	Mast	Maximum fork height	in (mm)	118 (3000)	118 (3000)	118 (3000)
	11		Mast lowered (OHL)	in (mm)	98.5 (2500)	106.3 (2700)	112.2 (2850)
	12		Mast extended w/ LBR	in (mm)	174.1 (4420)	174.1 (4420)	170.5 (4330)
	13		Standard freelif	in (mm)	8.4 (210)	8.0 (205)	8.1 (205)
	14	Fork Size	Length x thickness x width	in (mm)	48 x 6 x 2.8 (1220 x 150 x 70)	48 x 6 x 2.8 (1220 x 150 x 70)	48 x 7.1 x 3 (1220 x 180 x 75)
	15	Tilt Angle	Standard mast - fwd/back	degree	6 / 12	6 / 12	6 / 12
	16	Overall Dimensions	Length (to face of forks)	in (mm)	143.3 (3640)	156.7 (3980)	167.1 (4245)
	17		Height - top of OHG	in (mm)	99.6 (2530)	103.9 (2640)	103.9 (2640)
	18		Height - top of standard LBR	in (mm)	53.7 (1365)	53.5 (1360)	—
	19		Width - standard carriage	in (mm)	72.6 (1845)	79.3 (2015)	—
	20	Overall Width		in (mm)	78.5 (1995)	85.2 (2165)	88.4 (2245)
	21	Rear Overhang		in (mm)	30.1 (765)	30 (760)	28.9 (735)
	22	Turning Radius	Minimum outside	in (mm)	133.1 (3380)	142.9 (3630)	152.8 (3880)
	23	Min Right Angle Stack	Add load length & clearance	in (mm)	157.7 (4005)	171.2 (4350)	180.8 (4595)
PERFORMANCE	24	Travel Speed Forward	Maximum - loaded / unloaded	mph (km/h)	18 / 19.2 (29 / 31)	17.7 / 19.9 (28.5 / 32)	17.7 / 19.9 (28.5 / 32)
	25	Lifting Speed	Maximum - loaded / unloaded	fpm (mm/sec)	98.4 / 102.4 (500 / 520)	88.6 / 92.5 (450 / 470)	74.8 / 78.7 (380 / 400)
	26	Lowering Speed	Maximum - loaded / unloaded	fpm (mm/sec)	88.6 / 98.4 (450 / 500)	88.6 / 88.6 (450 / 450)	88.6 / 68.9 (450 / 350)
	27	Drawbar Pull Maximum	Full load - at 1 mph	lb (kN)	12,300 (54.9)	13,500 (59.8)	14,300 (63.7)
	28		No load - at 1 mph	lb (kN)	4900 (21.6)	6200 (27.5)	7100 (31.4)
	29	Gradeability Maximum	Full load / no load - at 1 mph	%	31 / 16	28 / 20	22 / 20
WEIGHT	30	Truck Weight	No load - standard truck	lb (kg)	21,120 (9580)	24,810 (11,250)	27,630 (12,530)
	31	Weight Distribution	Front axle - empty	lb (kg)	8510 (3860)	10,830 (4910)	12,630 (5730)
	32		Rear axle - empty	lb (kg)	12,610 (5720)	13,980 (6340)	14,990 (6800)
	33		Front axle - with rated load	lb (kg)	32,350 (14,670)	37,770 (17,130)	44,980 (20,400)
	34		Rear axle - with rated load	lb (kg)	4210 (1910)	4670 (2120)	4700 (2130)
CHASSIS & WHEELS	35	Wheelbase		in (mm)	88.6 (2250)	98.4 (2500)	110.2 (2800)
	36	Tires	Number (front/rear)		4 / 2	4 / 2	4 / 2
	37		Front size		8.25 x 15 - 14 PR	9.00 x 20 - 14 PR	9.00 x 20 - 14 PR
	38		Rear size		8.25 x 15 - 14 PR	9.00 x 20 - 14 PR	9.00 x 20 - 14 PR
	39	Tread - Center of Tire	Front	in (mm)	57.9 (1470)	63.0 (1600)	63.0 (1600)
	40						
	41		Rear Tread	in (mm)	66.9 (1700)	66.9 (1700)	66.9 (1700)
	42	Headroom		in (mm)	45.3 (1150)	45.3 (1150)	45.3 (1150)
	43	Counterweight Height		in (mm)	59.1 (1500)	63.4 (1610)	63.4 (1610)
	44	Floor Height		in (mm)	36.8 (935)	41.1 (1045)	41.1 (1045)
	45	Underclearance	Minimum full load/Center wheelbase	in (mm)	6.7 (170) / 9.6 (245)	8.5 (215) / 12.8 (325)	9.6 (245) / 12.8 (325)
46	Service Brake	Type		Foot, Hydraulic Boost	Foot, Hydraulic Boost	Foot, Hydraulic Boost	
47	Parking Brake	Type		Hand, Mechanical	Hand, Mechanical	Hand, Mechanical	
DRIVE LINE	48	Battery	Voltage / Capacity (5 Hour)		24/70	24/70	24/70
	49	Engine	Model		Isuzu 4HKI-TC	Isuzu 4HKI-TC	Isuzu 4HKI-TC
	50	Rated Output	SAE gross	hp(kW)@rpm	117 (87) @ 2000	117 (87) @ 2000	117 (87) @ 2000
	51	Rated Torque	SAE gross	ft-lb(Nm)@rpm	359 (487) @ 1500	359 (487) @ 1500	359 (487) @ 1500
	52	Displacement		cu in (L)	317 (5.2)	317 (5.2)	317 (5.2)
	53	Fuel Tank	Capacity	1 gal (L)	37 (140)	37 (140)	37 (140)
	54	Transmissions	Type / # Speeds (frwd/rev)		Automatic Powershift - 2/2	Automatic Powershift - 2/2	Automatic Powershift - 2/2
	55	Operating Pressure	For attachment	(kg/cm ³)	2844 (200)	2844 (200)	2844 (200)

DIMENSIONS

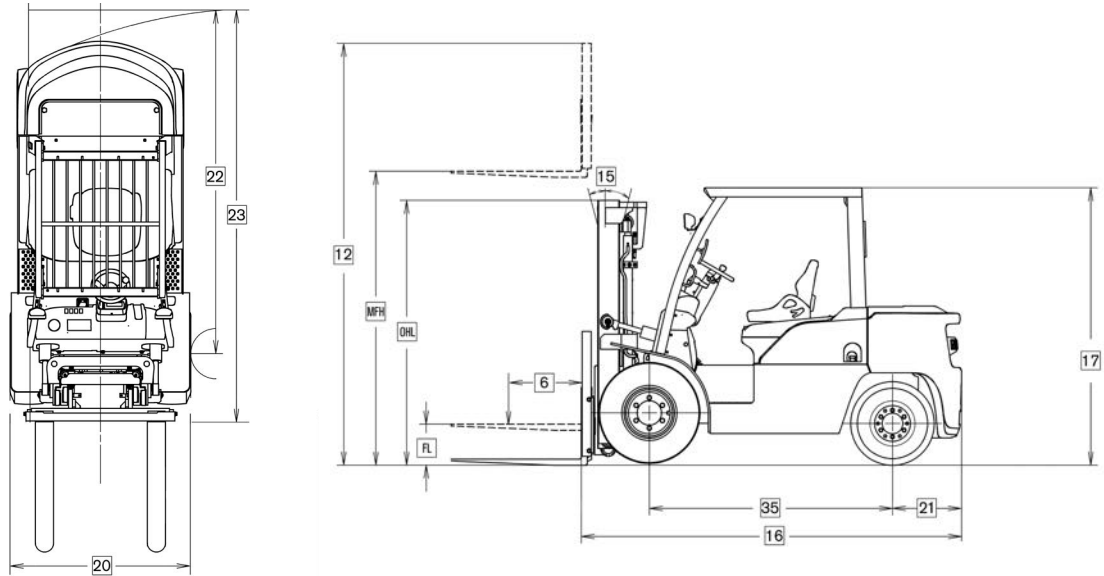

MAST SPECIFICATIONS & RATED CAPACITIES

Mast Type	Mast Name	Maximum Fork Height	Overall Height				Free Lift		Tilt Angle	Rated Capacity at 24" Load Center	
			Lowered	Fully Extended		With LBR	Without LBR	Fwd/Bkwd	FD70-2		
				With LBR	Without LBR				Dual Drive		
		in (mm)	in (mm)	in (mm)	in (mm)	in (mm)	in (mm)	deg	lb (kg)		
TWO STAGE (Wide view)	2W300	118 (3000)	98.5 (2500)	174.1 (4422)	162.3 (4122)	8.4 (213)	8.4 (213)	6/12	15500 (7030)		
	2W330	130 (3300)	104.4 (2650)	185.9 (4722)	174.1 (4422)	8.4 (213)	8.4 (213)	6/12	15500 (7030)		
	2W350	138 (3500)	108.3 (2750)	193.8 (4922)	181.9 (4618)	8.4 (213)	8.4 (213)	6/12	15500 (7030)		
	2W400	157 (4000)	120.1 (3050)	213.4 (5420)	201.6 (5120)	8.4 (213)	8.4 (213)	6/12	15500 (7030)		
	2W450	177 (4500)	130.0 (3300)	233.1 (5920)	221.3 (5621)	8.4 (213)	8.4 (213)	6/12	15500 (7030)		
	2W500	197 (5000)	139.8 (3550)	252.8 (6421)	241.0 (6122)	8.4 (213)	8.4 (213)	6/6	15500 (7030)		
	2W550	216 (5500)	151.6 (3850)	272.5 (6922)	260.7 (6622)	8.4 (213)	8.4 (213)	3/6	14500 (6575)		
	2W600	236 (6000)	161.5 (4100)	292.2 (7422)	280.4 (7112)	8.4 (213)	8.4 (213)	3/6	14100 (6395)		
TWO STAGE (Full free)	2F300	118 (3000)	103.4 (2625)	174.1 (4422)	161.3 (4100)	49.4 (1255)	62.2 (1552)	6/12	15500 (7030)		
	2F330	130 (3300)	109.3 (2775)	185.9 (4722)	173.1 (4396)	55.3 (1405)	68.1 (1730)	6/12	15500 (7030)		
	2F350	138 (3500)	113.2 (2875)	193.8 (4922)	181.0 (4597)	59.2 (1504)	72.0 (1829)	6/12	15500 (7030)		
	2F400	157 (4000)	125.0 (3175)	213.4 (5420)	200.6 (5095)	71.0 (1803)	83.8 (2129)	6/12	15500 (7030)		
	2F450	177 (4500)	134.9 (3425)	233.1 (5920)	220.3 (5595)	80.9 (2055)	93.7 (2380)	6/12	15500 (7030)		
THREE STAGE (Full free)	3F400	157 (4000)	98.5 (2500)	212.6 (5400)	199.9 (5077)	44.4 (1128)	57.2 (1453)	6/10	13650 (6190)		
	3F435	169 (4300)	103.4 (2625)	226.4 (5740)	213.6 (5425)	49.4 (1255)	62.2 (1552)	6/10	13650 (6190)		
	3F480	189 (4750)	109.3 (2775)	238.2 (6050)	231.3 (5875)	55.3 (1405)	68.1 (1730)	6/10	13650 (6190)		
	3F500	197 (5000)	113.2 (2875)	252.0 (6400)	239.2 (6076)	59.2 (1504)	72.0 (1829)	6/10	13650 (6190)		
	3F600	236 (6000)	130.0 (3300)	291.4 (7402)	278.6 (7076)	75.9 (1928)	88.7 (2130)	3/6	12125 (5500)		
	3F700	276 (7000)	144.7 (3675)	330.8 (8402)	318.0 (8077)	90.7 (2304)	103.5 (2629)	3/6	8150 (3700)		
	3F800	315 (8000)	161.5 (4100)	370.1 (9400)	357.3 (9075)	107.4 (2728)	120.2 (3053)	3/6	5050 (2290)		

MAST SPECIFICATIONS & RATED CAPACITIES

Mast Type	Mast Name	Maximum Fork Height	Overall Height				Free Lift		Tilt Angle	Rated Capacity at 24" Load Center
			Lowered	Fully Extended		With LBR	Without LBR	Fwd/Bkwd	FD80-2	
				With LBR	Without LBR				Dual Drive	
				in (mm)	in (mm)				in (mm)	in (mm)
TWO STAGE (Wide view)	2W300	118 (3000)	106.3 (2700)	174.1 (4422)	164.6 (4180)	8.0 (203)	8.0 (203)	6/12	17500 (7940)	
	2W330	130 (3300)	112.3 (2852)	185.9 (4722)	176.4 (4481)	8.0 (203)	8.0 (203)	6/12	17500 (7940)	
	2W350	138 (3500)	116.2 (2952)	193.8 (4922)	184.3 (4681)	8.0 (203)	8.0 (203)	6/12	17500 (7940)	
	2W400	157 (4000)	128.0 (3251)	213.4 (5420)	204.0 (5182)	8.0 (203)	8.0 (203)	6/12	17500 (7940)	
	2W450	177 (4500)	137.8 (3500)	233.1 (5920)	223.7 (5682)	8.0 (203)	8.0 (203)	6/12	17500 (7940)	
	2W500	197 (5000)	147.7 (3752)	252.8 (6421)	243.4 (6182)	8.0 (203)	8.0 (203)	6/6	17500 (7940)	
	2W550	216 (5500)	159.5 (4051)	272.5 (6922)	263.0 (6680)	8.0 (203)	8.0 (203)	3/6	16300 (7395)	
TWO STAGE (Full free)	2F300	118 (3000)	106.3 (2700)	174.1 (4422)	166.0 (4216)	52.9 (1344)	61.0 (1550)	6/12	17500 (7940)	
	2F330	130 (3300)	112.3 (2852)	185.9 (4722)	177.8 (4516)	58.8 (1494)	66.9 (1700)	6/12	17500 (7940)	
	2F350	138 (3500)	116.2 (2952)	193.8 (4922)	185.7 (4717)	62.7 (1592)	70.8 (1798)	6/12	17500 (7940)	
	2F400	157 (4000)	128.0 (3251)	213.4 (5420)	205.4 (5217)	74.6 (1895)	82.6 (2098)	6/12	17500 (7940)	
	2F450	177 (4500)	137.8 (3500)	233.1 (5920)	225.0 (5717)	84.4 (2144)	92.5 (2350)	6/12	17500 (7940)	
THREE STAGE (Full free)	3F400	157 (4000)	101.4 (2576)	212.6 (5400)	204.6 (5197)	48.0 (1219)	56.1 (1425)	6/10	15450 (7000)	
	3F435	169 (4300)	106.3 (2700)	226.4 (5740)	218.4 (5547)	52.9 (1344)	61.0 (1550)	6/10	15450 (7000)	
	3F480	189 (4750)	112.3 (2852)	238.2 (6050)	236.1 (5997)	58.8 (1494)	66.9 (1700)	6/10	15450 (7000)	
	3F500	197 (5000)	116.2 (2952)	252.0 (6400)	243.9 (6195)	62.5 (1590)	70.6 (1795)	6/10	15450 (7000)	
	3F600	236 (6000)	132.9 (3376)	291.4 (7402)	283.3 (7196)	79.5 (2019)	87.5 (2222)	3/6	13250 (6010)	
	3F700	276 (7000)	147.7 (3752)	330.8 (8402)	322.7 (8197)	94.2 (2393)	102.3 (2598)	3/6	9900 (4490)	
	3F800	315 (8000)	164.4 (4176)	370.1 (9400)	362.1 (9197)	111.0 (2819)	119.0 (3023)	3/6	5500 (2495)	

MAST SPECIFICATIONS & RATED CAPACITIES

Mast Type	Mast Name	Maximum Fork Height	Overall Height			Free Lift		Tilt Angle	Rated Capacity at 24" Load Center
			Lowered	Fully Extended		With LBR	Without LBR	Fwd/Bkwd	FD100-2
				With LBR	Without LBR				Dual Drive
				in (mm)	in (mm)				in (mm)
TWO STAGE (Wide view)	2W300	118 (3000)	112.2 (2850)	170.5 (4330)	170.5 (4330)	8.1 (205)	8.1 (205)	6/12	22000 (10000)
	2W350	138 (3500)	122.2 (4920)	190.2 (4830)	190.2 (4830)	8.1 (205)	8.1 (205)	6/12	22000 (10000)
	2W400	157 (4000)	133.9 (3400)	209.8 (5330)	209.8 (5330)	8.1 (205)	8.1 (205)	6/12	22000 (10000)
	2W450	177 (4500)	143.7 (3650)	229.5 (5830)	229.5 (5830)	8.1 (205)	8.1 (205)	6/12	22000 (10000)
	2W500	197 (5000)	153.5 (3900)	249.2 (6330)	249.2 (6330)	8.1 (205)	8.1 (205)	6/6	22000 (10000)
	2W550	216 (5500)	165.4 (4200)	268.9 (6830)	268.9 (6830)	8.1 (205)	8.1 (205)	3/6	19800 (9000)
	2W600	236 (6000)	175.2 (4450)	288.6 (7330)	288.6 (7330)	8.1 (205)	8.1 (205)	3/6	17500 (8000)

STANDARD EQUIPMENT

- EPA/CARB certified - Isuzu Diesel Engine with electronic engine control and common rail fuel injection
- Turbocharger with intercooler
- 2-speed, automatic transmission with full floating powertrain for reduced vibration
- Engine temperature protection and warning system to safeguard your investment
- Transmission mode selector - high speed / low speed / first gear
- Heavy-duty, cushion mounted radiator w/transmission oil cooler
- Large engine oil filter
- Dual fuel filters
- Seat actuated Operator Presence System includes return-to-neutral power interrupt with parking brake and seatbelt warnings
- Full suspension seat with operator restraint system
- Tilt-adjustable steering wheel
- Cushioned rubber floor mat
- Horn, back-up alarm, and dual rearview mirrors
- OHG-mounted headlights and front turn signals
- Rear combination lights – tail, brake, and back-up
- Easi-view meter panel with LCD display and long-life LED indicators
- Hour meter and check engine warning
- Engine glow plug preheating indicator
- Engine coolant temperature gauge with low coolant level warning light
- Transmission oil temperature gauge
- Low engine oil pressure warning
- Transmission neutral indicator
- Fuel gauge with low fuel level warning
- Battery charge warning
- Air cleaner clogging warning
- Anti-restart ignition with neutral-start system
- Drive-by-wire accelerator control
- Hydrostatic power steering system
- Hydraulic boosted brakes with pressure accumulator
- 3-spool hydraulic control valve
- High air intake system with large cyclone air filter
- 5-piece overhead guard
- Dual drive tires

OPTIONAL EQUIPMENT

- Solid pneumatic tires
- Air intake pre-cleaner
- Radiator screen
- Overhead exhaust muffler
- Steering synchronized-knob position control
- Tilt cylinder boots
- Rear work light
- Strobe light

OPERATOR COMFORT & CONTROL

Enhanced comfort results from the Platinum G06 Series' Operator Comfort System, which includes a full suspension seat, cushion floor mat, pedals mounted to the chassis frame, and rubber shock absorbers located throughout the vehicle to reduce vibration from the engine and transmission to the operator. The Platinum G06 Series' floating powertrain design incorporates rubber engine/transmission supports, for additional vibration reduction.

A spacious operator compartment provides generous foot, leg and head room for a variety of driver sizes. The standard full suspension seat with soft touch hip restraints provides maximum operator comfort. Its low profile design offers ample head clearance, while front to back travel adjustment allows a comfortable, customized fit for nearly any operator height.

The Platinum G06's tilt-adjustable steering wheel helps the operator quickly find his or her ideal driving position, while its compact design offers enhanced control and handling. Hydrostatic power steering provides superior response for enhanced maneuverability, while minimizing steer effort for low operator fatigue.

Hydraulic boosted brakes offer reduced pedal effort, resulting in enhanced operator comfort and control. The electric directional control lever makes it easy to change the direction of travel. Automotive-style light and turn signal levers provide easy operation, allowing the operator to focus on the job.

ENHANCED WORK ENVIRONMENT

Several standard features are included in the Platinum G06 Series to deliver a more comfortable and productive work environment for the operator and those in the surrounding area.

For easy entry/exit, the left front pillar's assist grip, combined with a low, wide entry step, with non-skid coating, and a wide, metal traction plate second step, provide the operator with sure, comfortable footing and grip for this often repeated task.

A wide-view carriage offers improved forward visibility with improved fork tip visibility for enhanced operation. The Easi-view meter panel, with LCD display and bright, long-life LED indicators, provides the operator with excellent visibility and understanding of warning indicators.

The G06's two-speed, automatic transmission reduces shift shock due to shortened shift time lag. The standard transmission mode selector allows the operator to switch between low speed, high speed, or first gear travel.

The Platinum G06's Operator Presence System, with seat actuated power interrupt, incorporates a mast-lock which automatically locks lift and tilt operations when the operator leaves the seat, and a return to neutral feature to minimize forklift movement if the operator leaves the seat while the lift truck is still in gear. This presence system also includes warnings if either the seat belt is not engaged, or when the parking brake has not been applied prior to the operator exiting the compartment. Note, the return-to-neutral system only shifts the transmission into neutral; it does not engage the brakes.

EASE OF MAINTENANCE

Built-in diagnostics will display warning lights and gauges on the truck's instrument panel to provide truck status. Tilt cylinders grease points are conveniently located for easy lubrication. The two-piece, front and rear, floorboards are easily removed and reinstalled, without tools, promoting simple access to the transmission and hydraulic components. A wide-open clamshell hood provides a roomy area for service technicians to perform their tasks. The five-piece reinforced overhead guard simplifies replacement of individual components if necessary, saving time and money.

ADVANCED ENGINE TECHNOLOGY

Platinum G06 Series are powered by an Isuzu 4HK1-TC, 5.2-liter, industrial diesel engine. The combination of electronic fuel injection and engine turbo charging technology results in higher power and increased efficiency, with emission levels well below EPA Tier III requirements.

The engine's single overhead cam (SOHC) and 16 valve (four valves per cylinder) design maximizes the air flow into and out of the engine, providing highly efficient optimization of the fuel, air, and exhaust flow, resulting in improved fuel efficiency by increasing air intake and discharge efficiency. Maximum horsepower and torque at low rpm results in increased engine durability.

As an added safeguard for your investment, the Platinum G06 includes an engine protection and warning system to reduce engine rpm in the event of excessive heat generation. An electronically regulated, Quick Glow System results in considerably reduced glow times, providing faster engine starting in cold weather.

ELECTRONIC FUEL INJECTION

An electronic, common rail fuel injection system analyzes engine performance parameters and optimizes engine operation, resulting in enhanced productivity and lower fuel consumption. The diesel engine control module (DCM) uses a feedback loop to respond to sensor input to control engine related functions, such as proper air/fuel ratio, injection timing, and speed, based on the requirements of the application.

The common rail, high-pressure fuel injection system improves combustion efficiency by ultra high-pressure fuel injection. With common rail injection technology, the fuel injector for each cylinder is constantly provided with extremely high pressure fuel from the rail. The DCM controls the injection pulses to regulate the injection timing and the amount of fuel injected into each cylinder, for optimized fuel combustion. This electronic control offers improved fuel consumption, substantially lower emissions of nitrogen oxides (NOx) and near elimination of particulate matter.

INTERCOOLED TURBO DIESEL

The G06 Series' engine turbocharger and intercooler increases the engine's rated output for high productivity. The turbo creates more power by force-feeding compressed air to the cylinders. The turbocharger system provides constant boost pressure over the entire rpm range, for excellent torque at low speeds. To maximize the benefits of the turbo-charger, an intercooler chills the compressed air, for a denser intake charge, allowing for greater combustion and increased power output.

COOLED EXHAUST GAS RECIRCULATION (EGR) SYSTEM

The exhaust gas recirculation system (EGR) returns a measured amount of exhaust gas back to the combustion chamber, to reduce the combustion temperature and reduce the concentration of oxygen in the combustion chamber, reducing the formation of nitrogen oxide (NOx). An EGR cooler reduces the exhaust temperature prior to mixing into the intake stream, preventing loss of air charge density.

DURABLE DESIGN FEATURES

The G06 Series is built for toughness, with a robust mast, strong frame, thick steel fenders, and heavy-duty drive and steer axles. The wide-opening engine hood features gas strut supports for easy opening/closing. A detent on one strut helps keep the hood open during servicing. Insulation under the hood helps reduce noise for a more comfortable ride for the operator.

The G06 features transmission driven, triple hydraulic pumps providing enhanced efficiency, durability and accessibility. One pump is used for lifting and load handling, one pump for the power steering system, and a third pump for the hydraulically boosted brake system. A priority load sensing control valve allows excess hydraulic fluid from the steering system to supply hydraulic oil to the lift system for increased lift speeds.

The G06's superior cooling system consists of an oversized fan and wide cooling outlet, for enhanced airflow. The heavy-duty radiator, with transmission oil cooler, is rubber mounted to reduce flexing and absorb vibration for enhanced reliability. The improved cooling capacity translates into dependable cooling efficiency under heavy usage or high ambient temperatures. A cyclone air cleaner helps extend filter life, while a sensor on the dash panel will indicate inadequate airflow, to help prevent overheating.

A heavy-duty steer axle protects the steer cylinder from damage. The rear axle includes grease fittings for easy lubrication to provide longer life and steering ease.

Lift cylinders include oil return piping for reduced heat generation and extended life. The mast's rugged precision ball bearings deliver smooth operation and maximum control while telescoping. A flow control valve restricts the lowering speed of the mast in the event hose pressure is lost. Tilt lock valves give smooth mast tilt operation in both directions.



UniCarriersAmericas.com

SS-G06 09-2015 Printed in U.S.A.

UniCarriers® is a registered trademark of UniCarriers Corporation. Platinum® is a registered trademark of UniCarriers Americas. UniCarriers Americas Corporation reserves the right to make product changes relating to colors, equipment, specifications or available options without notice. For more information, contact your UniCarriers representative.

