

KOMATSU®

3,000 to 4,500 lb Capacity

Advanced AC Technology

FR Series FR15K/FR18K/FR23K

NARROW AISLE SINGLE & DOUBLE REACH

Features and Specifications



The Forklift With Proven Ability.™



Step Into The KOMFORT ZONE™!

Komatsu's FR Series of narrow aisle reach trucks feature new and innovative engineering ideas that show Komatsu's commitment to conserving our environment, and reducing your overall costs of ownership. AC drive and hydraulic controls offer smooth and efficient control of critical trucks functions, while giving you extended run times and improved truck efficiencies.



Key truck features include:

- KICS AC Control – Komatsu Intelligent Control System for smart control of truck AC drive and AC lift systems
- Efficient, responsive, low-effort steer-by-wire system with straight-line stability and speed sensing control
- Multi-function control handle for efficient and precise control of travel direction and speed; lift, reach, tilt, and sideshift; and horn
- Smooth and seamless proportional hydraulic control
- Re-generative systems to re-capture current during plugging; accelerator off; brake pedal on; and lifting operation off
- Maintenance-free electromagnetic disc brake
- Rugged and dependable heavy-duty mast and pantograph mechanism to handle the toughest work cycles

AC
POWERED
SYSTEMS

Models

FR18K/FR23K – Single Reach
3,500 / 4,500 lb. Capacity

FR15K – Double Reach
3,000 lb. Capacity

A New Level of Operator Komfort

Komatsu's new narrow aisle reach trucks bring operator comforts and efficiencies to a new level.

- Low step height, spacious cushioned floorboard, and ample padding, for greater levels of operator productivity while remaining alert and ready to work
- Side-stance operator positioning provides maximum visibility for both load handling and directional travel
- Short steer arm and electrical steer-by-wire technology for virtually effortless maneuvering
- Multi-function control handle offers intuitive control and ease of use for travel direction and speed as well as all hydraulic functions
- Cushioned rubber floor mat and rubber padded brake release pedal and operator presence pedal add to operator comfort
- Armrest pad, knee pad, and lower back pad provide added comfort and support for extended work periods



Electronic steer-by-wire system with small diameter steer tiller arm provides quiet, responsive maneuvering



An ergonomically designed multi-function control handle offers easy and intuitive control of truck drive and hydraulic functions.

Greater Productivity

When gauging truck productivity, it is important to look at overall cycle times necessary to perform in the workplace. With the FR Series, you have an exceptional blend of fast and efficient proportional hydraulic operation, responsive steer-by-wire maneuvering, and rugged and dependable drive system that allows for quick and efficient operation.

The FR Series models feature Komatsu's intelligent KICS AC system to effectively reduce total operating costs while improving productivity and reliability.

- Customized speed settings and controller flexibility allow you match the truck to your operator and application needs
- Efficient control layout, small/easy to control steering tiller
- Multi-function control handle
- Advanced AC technologies increase run times and allow for more work between battery charges
- Oil flow is accurately measured and infinitely controlled

Proportional Hydraulic Control Valve System

Oil flow is accurately measured and infinitely controlled through a combination of the truck controller and the proportional control valve. Infinitely variable hydraulic control speed allows for smooth, full-feathering of hydraulic movements as well as minimal shocks, making the FR Series ideal for handling sensitive and fragile materials.

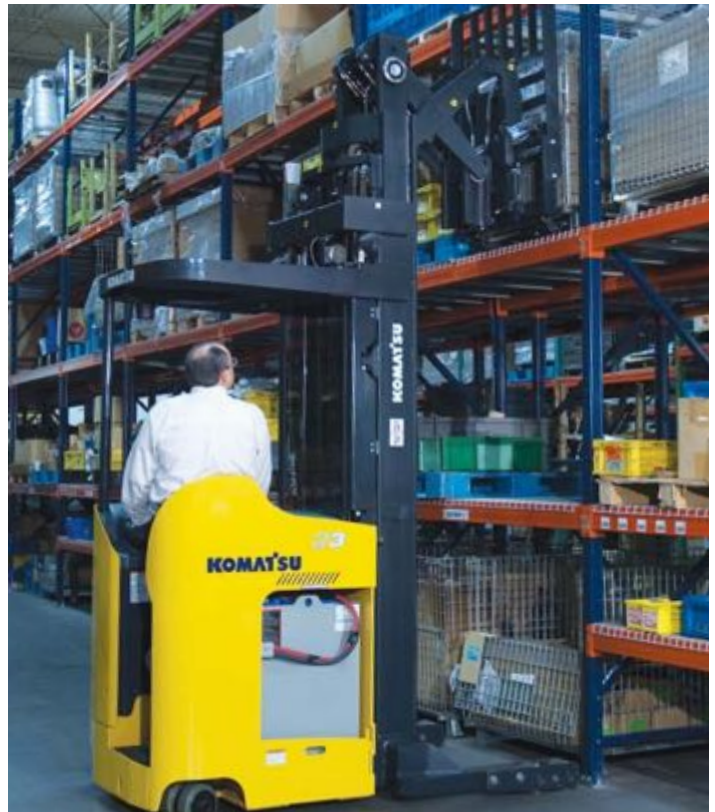

Low Total Operating Costs Add To Your Bottom Line

Heavy-Duty Mast and Reach Carriage

The Komatsu FR Series uses tested and reliable components to reduce your overall cost of operation. The three stage mast and reach carriage features a rugged design that will deliver dependable service for the long haul. Mast features include:



- Interlocking channel and I-beam design for excellent visibility and strength
- Canted rollers and sealed bearings for smooth and dependable operation
- Dual reach cylinders nested within the reach arm frame for greater protection
- Hydraulic cushioning within the retract function for added protection of fragile loads
- Outriggers are welded to the mast outer channel and reinforced for added strength and support
- Bolt-on load wheel outrigger toe boxes allow quick and easy load wheel replacement with minimal downtime

Minimal Maintenance Costs With Komatsu's Advanced AC Technology

The advanced and intelligent KICS AC control system has (1) advanced technology AC drive motor and (1) AC hydraulic motor to achieve high performance with minimal costs.



- AC motors eliminate the need for motor brush checks or replacements
- AC motors provide high operating efficiency, long operating life, and longer run times than conventional DC type motors
- A power saver function enhances the truck's ability to achieve longer run times without reducing productivity or performance

Keypad Communication

A keypad on the dash communicates truck settings and on-board diagnostics. Truck performance settings can be adjusted through the keypad to achieve optimal performance parameters for your application needs. The keypad also displays state-of-battery charge, time of day, and travel speed.



Electric Disc Brake System

An electric disc brake system on top of the drive motor armature shaft provides for smooth and consistent stops when releasing the brake pedal. Normal travel braking is usually accomplished through the process of "plugging" or reversing the direction of travel through the drive system.



- The operator steps down on the rubber cushioned, floor mounted brake pedal and electrically releases the brake
- When the operator steps off of the truck, the raised pedal automatically applies the parking brake

Serviceability – Quick and Simple to Reduce Your Downtime

FR Series models feature a start-up diagnostic system at power-on to check all major components and systems prior to allowing the unit to be operated. The control system has a built-in analyzer that can provide feedback on fault detection and other diagnostics. No external analyzer is needed. Other simplified maintenance features include:



- Easily removable lift-off panels provide easy access to the truck's control system
- Swing-open side door provides access to the drive motor, drive unit, electrical disc brake, and the steer-by-wire system
- Bolt-on outrigger toe boxes for quick load wheel change-outs
- Frame cut-out for easy drive tire replacement
- Removable panel for caster wheel adjustments

Overall service is greatly reduced by advanced AC technologies, advanced designs, and forethought to component placement, thereby reducing your overall costs of ownership.

Standard & Optional Equipment

● Standard Equipment ○ Available Optional Equipment

	FR18K	FR23K	FR15K
Vehicle Management			
AC motor controller w/built-in self-diagnostics	●	●	●
Multi-function LED display	●	●	●
Battery discharge indicator with lift interrupt	●	●	●
Four individual hour meter readings	●	●	●
Multi-function control handle	●	●	●
Emergency power disconnect switch	●	●	●
Motor and controller temperature protection	●	●	●
Automatic fork height selector	○	○	○
Digital fork height indicator	○	○	○
Chassis & Mast			
AC drive motor	●	●	●
36-volt electrical system	●	●	●
Battery compartment rollers and side gates	●	●	●
Three-stage mast: 95" OHL / 210" MFH	●	●	●
48" high load backrest	●	●	●
U.L. "EE" Rating ¹	○	○	○
Outriggers			
33" - 50" I.D. base legs	●	●	●
5" x 4" tandem load wheels	●	●	●
10.5" x 4" single load wheels	○	○	○
5" x 3" tandem narrow load wheels	○	○	○
4" x 3" tandem low profile load wheels	○	○	○
Tapered outrigger tips (load wheel guard)	○	○	○

	FR18K	FR23K	FR15K
Vehicle Management			
Operator Presence System			
Operator presence pedal with mast lockout and return-to-neutral	●	●	●
Brake pedal (depress to travel)	●	●	●
Steering System			
On-demand electronic power steering	●	●	●
Small radius tiller control	●	●	●
Steer tire position indicator	●	●	●
Brake			
4-mode regen braking	●	●	●
Automatic parking brake with anti-rollback	●	●	●
Hydraulic System			
AC hydraulic pump motor	●	●	●
Proportional lift and lower	●	●	●
Operator Conveniences			
90° operator side stance	●	●	●
Anti-fatigue arm, knees and back padding	●	●	●
Adjustable operator backrest cushion	●	●	●
Safety glass mast guard	●	●	●
Operator fan and light	○	○	○
Front or rear work lights	○	○	○
Strobe lights	○	○	○
Wire mesh mast guard	○	○	○

(1) U.L. "EE" rating available with 16.4" battery box only

Right Angle Stacking Aisle Widths in. (mm)

FR18K	Load Width					
Load Length	30"	36"	40"	42"	44"	48"
30"	83" (2108)	82" (2083)	81" (2057)	80" (2032)	80" (2032)	79" (2007)
36"	91" (2311)	91" (2311)	90" (2286)	90" (2286)	90" (2286)	89" (2261)
40"	96" (2438)	95" (2413)	95" (2413)	95" (2413)	95" (2413)	94" (2388)
42"	98" (2489)	98" (2489)	97" (2464)	97" (2464)	97" (2464)	97" (2464)
44"	100" (2540)	100" (2540)	100" (2540)	99" (2515)	99" (2515)	99" (2515)
48"	105" (2667)	104" (2642)	104" (2642)	104" (2642)	104" (2642)	103" (2616)

16.4" Battery Compartment; Add minimum of 6" for clearance and ease of operation.

FR23K	Load Width					
Load Length	30"	36"	40"	42"	44"	48"
30"	90" (2286)	88" (2235)	87" (2210)	87" (2210)	86" (2184)	85" (2159)
36"	97" (2464)	97" (2464)	96" (2438)	96" (2438)	96" (2438)	95" (2413)
40"	102" (2591)	101" (2565)	101" (2565)	101" (2565)	101" (2565)	100" (2540)
42"	104" (2642)	104" (2642)	103" (2616)	103" (2616)	103" (2616)	103" (2616)
44"	106" (2692)	106" (2692)	106" (2692)	105" (2667)	105" (2667)	105" (2667)
48"	111" (2819)	110" (2794)	110" (2794)	110" (2794)	110" (2794)	109" (2769)

20.9" Battery Compartment; Add minimum of 6" for clearance and ease of operation.

FR15K	Load Width					
Load Length	30"	36"	40"	42"	44"	48"
30"	97" (2464)	96" (2438)	96" (2438)	96" (2438)	95" (2413)	95" (2413)
36"	104" (2642)	104" (2642)	103" (2616)	103" (2616)	103" (2616)	102" (2591)
40"	108" (2743)	108" (2743)	108" (2743)	108" (2743)	107" (2718)	107" (2718)
42"	111" (2819)	110" (2794)	110" (2794)	110" (2794)	110" (2794)	109" (2769)
44"	113" (2870)	112" (2845)	112" (2845)	112" (2845)	112" (2845)	112" (2845)
48"	117" (2972)	117" (2972)	116" (2946)	116" (2946)	116" (2946)	116" (2946)

20.9" Battery Compartment; Add minimum of 6" for clearance and ease of operation.

GENERAL		FR18K	FR23K	FR15K
1	Power Type	Electric	Electric	Electric
2	Operation Type	Stand-Up	Stand-Up	Stand-Up
3	Capacity @ 24 in. (600 mm) load center * lbs. (kg)	3,500 (1750)	4,500 (2250)	3,000 (1500)
WEIGHT				
4	Service weight (includes 210" mast, empty, no battery) lbs. (kg)	6,005 (2725)	6,420 (2915)	6,715 (3045)
TIRES & WHEELS				
5	Drive tire size - cushion rubber in. (mm)	13 x 5.5 (330 x 140)	13 x 5.5 (330 x 140)	13 x 5.5 (330 x 140)
6	Caster wheel size - dual polyurethane in. (mm)	7 x 2.87 (178 x 73)	7 x 2.87 (178 x 73)	7 x 2.87 (178 x 73)
7	Load wheel size - tandem polyurethane x 2 in. (mm)	5 x 4 (127 x 100)	5 x 4 (127 x 100)	5 x 4 (127 x 100)
DIMENSIONS				
8	Tilting angle - fork carriage, forward / backward deg.	3 / 4	3 / 4	3 / 4
9	Maximum fork height in. (mm)	210 (5335)	210 (5335)	210 (5335)
10	Mast height, lowered in. (mm)	95 (2415)	95 (2415)	95 (2415)
11	Free lift height in. (mm)	47.0 (1195)	47.2 (1200)	47.0 (1195)
12	Mast height, extended in. (mm)	260.3 (6615)	260.3 (6615)	260.3 (6615)
13	Height overhead guard in. (mm)	93.5 (2375)	93.5 (2375)	93.5 (2375)
14	Length, with Std. Forks in. (mm)	96.1 (2445)	97.6 (2485)	103.9 (2640)
15	Length to fork face — carriage retracted in. (mm)	54.1 (1375)	55.6 (1415)	61.9 (1570)
16	Maximum reach stroke in. (mm)	22.8 (580)	22.4 (570)	40.2 (1020)
17	Overall width, truck frame in. (mm)	43.0 (1090)	43.0 (1090)	43.0 (1090)
18	Overall width, outrigger I.D. (Min. - Max.) in. (mm)	33-50 (840-1270)	33-50 (840-1270)	33-50 (840-1270)
19	Overall width, outrigger O.D. (Min. - Max.) in. (mm)	44-61 (1120-1560)	44-60 (1120-1550)	44-60 (1120-1550)
20	Forks, thickness x width x length in.	1.5 x 4 x 42	1.75 x 4 x 42	1.5 x 4 x 42
21	Forks, thickness x width x length mm	40 x 100 x 1070	45 x 100 x 1070	40 x 100 x 1070
22	Carriage width / ITA Class ¹ in. (mm)	31.5 (800) / II	31.5 (800) / II	31.5 (800) / II
23	Step height in. (mm)	9.3 (235)	9.3 (235)	9.3 (235)
24	Ground clearance, under mast in. (mm)	2.0 (50)	2.0 (50)	2.0 (50)
25	Ground clearance, center of wheelbase in. (mm)	2.0 (50)	2.0 (50)	2.0 (50)
26	Wheelbase in. (mm)	59.0 (1500)	60.1 (1525)	62.0 (1575)
27	Right angle stacking aisle ¹ in. (mm)	100 (2540)	102 (2590)	108 (2745)
28	Turning radius, outside in. (mm)	69.4 (1760)	70.4 (1790)	72.4 (1840)
PERFORMANCE				
29	Travel speed, loaded - forks leading/forks trailing m/h	6.4 (10.3) / 7.2 (11.6)	6.4 (10.3) / 7.2 (11.6)	6.4 (10.3) / 7.2 (11.6)
30	Travel speed, unloaded - forks leading/forks trailing (km/h)	6.4 (10.3) / 7.2 (11.6)	6.4 (10.3) / 7.2 (11.6)	6.4 (10.3) / 7.2 (11.6)
31	Lifting speed, loaded / unloaded (mm/s)	70 (356) / 120 (610)	70 (356) / 120 (610)	70 (356) / 120 (610)
32	Lowering speed, loaded / unloaded (mm/s)	95 (483) / 87 (442)	95 (483) / 87 (442)	95 (483) / 95 (483)
MOTORS				
33	Drive motor (AC) hp (kW)	8.0 (6.0)	8.0 (6.0)	8.0 (6.0)
34	Pump motor (AC)	18.8 (14)	18.8 (14)	18.8 (14)
35	Power steering motor (DC)	0.5 (0.4)	0.5 (0.4)	0.5 (0.4)
BATTERY				
36	Battery voltage V	36	36	36
37	Battery capacity, maximum Ah/6hr	930	930	930
38	Battery compartment: Length in. (mm)	16.4 (415)	16.4 (415)	16.4 (415)
39	Width in. (mm)	38.7 (980)	38.7 (980)	38.7 (980)
40	Height in. (mm)	32 (810)	32 (810)	32 (810)
41	Minimum battery weight lbs. (kg)	2060 (935)	2060 (935)	2060 (935)
42	Maximum battery weight lbs. (kg)	2305 (1045)	2305 (1045)	2305 (1045)
OTHER				
43	Drive motor control	AC Inverter	AC Inverter	AC Inverter
44	Pump motor control	AC Inverter	AC Inverter	AC Inverter
45	Power steering motor control	Transistor Chopper	Transistor Chopper	Transistor Chopper
46	Steering type	On-demand, electric	On-demand, electric	On-demand, electric

NOTE: Most values shown in this publication are rounded. Therefore, direct conversion between metric and English or Imperial may be slightly different from those shown. The performance of machines is affected by the condition of the truck and how it is equipped, as well as the nature and condition of the operating area. If these specifications are critical or if your needs exceed the specifications shown here, discuss the proposed application with your authorized dealer.

*Optional masts, attachments, longer load dimensions, and higher lifting heights may result in downrating of the capacity. Contact your authorized dealer.

**Other mast heights available. See MAST DATA chart for other standard mast heights. Contact your authorized dealer.

¹ 48" L x 40" W pallet (add clearance) Contact your authorized dealer.

For Right Angle Stack, Add min. 6" Clearance for Ease of Operation. Contact your authorized dealer.

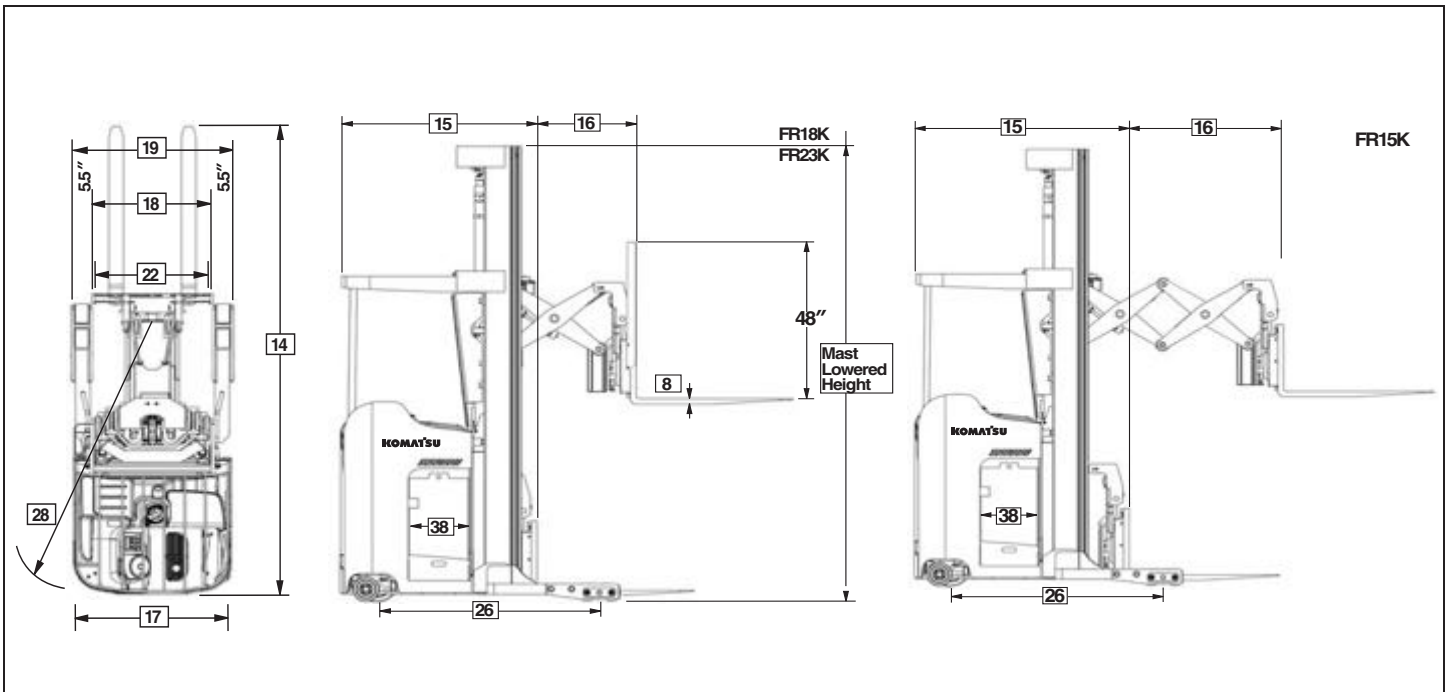

Mast Specifications

FR18K

Maximum Fork Height in. (mm)	Mast Height Lowered in. (mm)	Mast Height Extended in. (mm)	Free Lift in. (mm)	Tilt Angle Fwd/Bkwd (degree)
3-STAGE FULL FREE VIEW (TFV)				
198 (5030)	89 (2260)	247.8 (6295)	41.0 (1040)	3/4
210 (5335)	95 (2415)	260.3 (6615)	47.0 (1195)	3/4
240 (6095)	107 (2720)	290.4 (7380)	59.0 (1500)	3/4
270 (6860)	119 (3025)	320.5 (8140)	71.0 (1805)	3/4

Battery Compartments

Model	Length	Width	Height
FR18K	16.4" (417)	38.7" (984)	32" (813)
FR23K	16.4" (417)	38.7" (984)	32" (813)
	20.9" (531)	38.7" (984)	32" (813)
FR15K	16.4" (417)	38.7" (984)	32" (813)
	20.9" (531)	38.7" (984)	32" (813)

FR23K

Maximum Fork Height in. (mm)	Mast Height Lowered in. (mm)	Mast Height Extended in. (mm)	Free Lift in. (mm)	Tilt Angle Fwd/Bkwd (degree)
3-STAGE FULL FREE VIEW (TFV)				
198 (5030)	89 (2260)	247.8 (6295)	41.2 (1045)	3/4
210 (5335)	95 (2415)	260.3 (6615)	47.2 (1200)	3/4
240 (6095)	107 (2720)	290.4 (7380)	59.2 (1505)	3/4
258 (6555)	113 (2870)	308.4 (7835)	65.2 (1655)	3/4
270 (6860)	119 (3025)	320.5 (8140)	71.2 (1810)	3/4
300 (7620)	131 (3330)	350.6 (8905)	83.2 (2115)	3/4
330 (8380)	149 (3785)	380.5 (9665)	101.2 (2570)	3/4

FR15K

Maximum Fork Height in. (mm)	Mast Height Lowered in. (mm)	Mast Height Extended in. (mm)	Free Lift in. (mm)	Tilt Angle Fwd/Bkwd (degree)
3-STAGE FULL FREE VIEW (TFV)				
198 (5030)	89 (2260)	247.8 (6295)	41.0 (1040)	3/4
210 (5335)	95 (2415)	260.3 (6615)	47.0 (1195)	3/4
240 (6095)	107 (2720)	290.4 (7380)	59.0 (1500)	3/4
258 (6555)	113 (2870)	308.4 (7835)	65.0 (1650)	3/4
270 (6860)	119 (3025)	320.5 (8140)	71.0 (1805)	3/4
300 (7620)	131 (3330)	350.6 (8905)	83.0 (2110)	3/4
330 (8380)	149 (3785)	380.5 (9665)	101.0 (2565)	3/4

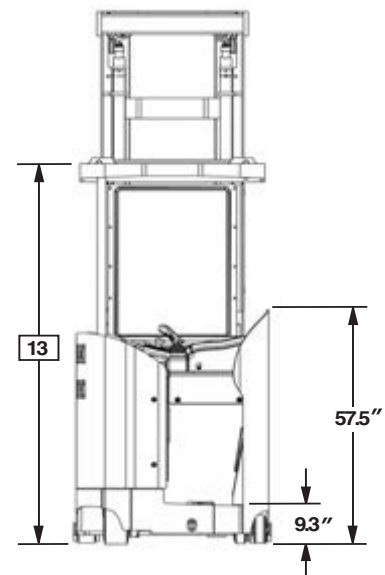

Building on our 80 year history of superior engineering, the FR Series delivers on productivity, reliability, and lower life-cycle costs while working your most demanding applications.

FR Series

NARROW AISLE SINGLE & DOUBLE REACH

STRONG CUSTOMER SATISFACTION

Komatsu Forklift has a strong corporate commitment to produce, deliver and support quality products, and we have always made customer satisfaction our top priority. We will work to the best of our ability to help you maximize your operation's productivity while minimizing costs.

QUALITY PRODUCTS & SERVICES

Komatsu Forklift offers an expanding product line of over 120 electric and internal combustion engine forklift models with capacities from 2,000 to 35,000 pounds. We back them with a complete warranty program, superior service, and genuine OEM parts.

CONTACT YOUR DEALER TODAY

Your nearby Komatsu Forklift dealer is ready to assist you. Ask about financing and leasing programs that can be tailored to your business plan. Forklifts for your specific applications and workplace are waiting for you now.

KOMATSU DEALER NETWORK

Komatsu Forklift has over 195 dealer locations throughout the United States, Canada, Mexico, the Caribbean, and Central and South America. Komatsu dealers are staffed with dedicated teams of professionals who are trained to meet your forklift needs.

THE KOMATSU HERITAGE

As part of the Komatsu family, we have a proud heritage of excellence in equipment design and manufacturing. Since 1921 Komatsu has been a global leader in the construction and mining equipment industry. And since 1945, we have built upon that heritage by producing innovative, high-quality, durable forklifts to meet and exceed the needs of our customers.



KOM82-00

©2011 Komatsu America Corp.

Printed in USA

D07(2.5M)CCI

7/11 (EV-1)

KOMATSU®

www.KomatsuAmerica.com

www.KomatsuForkliftUSA.com



Komatsu America Corp. is an authorized licensee of Komatsu Ltd. Materials and specifications are subject to change without notice.

Photos may include optional equipment. **KOMATSU** is a registered trademark of Komatsu Ltd., Japan